

NOTICE TO SHIPS BOUND FOR

SEPT-ILES

2023



IRON ORE COMPANY OF CANADA

Marine services

Sept-Iles, Quebec, Canada

IRON ORE COMPANY OF CANADA SEPT-ILES

The information in this booklet is provided as a matter of general information only. Iron Ore Company of Canada ("I.O.C.") and/or its servants and employees shall be relieved of any liability whatsoever, direct or indirect, for injury, loss of life, damage or loss of property arising out of any marine agency services provided by I.O.C. and summarily described in this booklet.

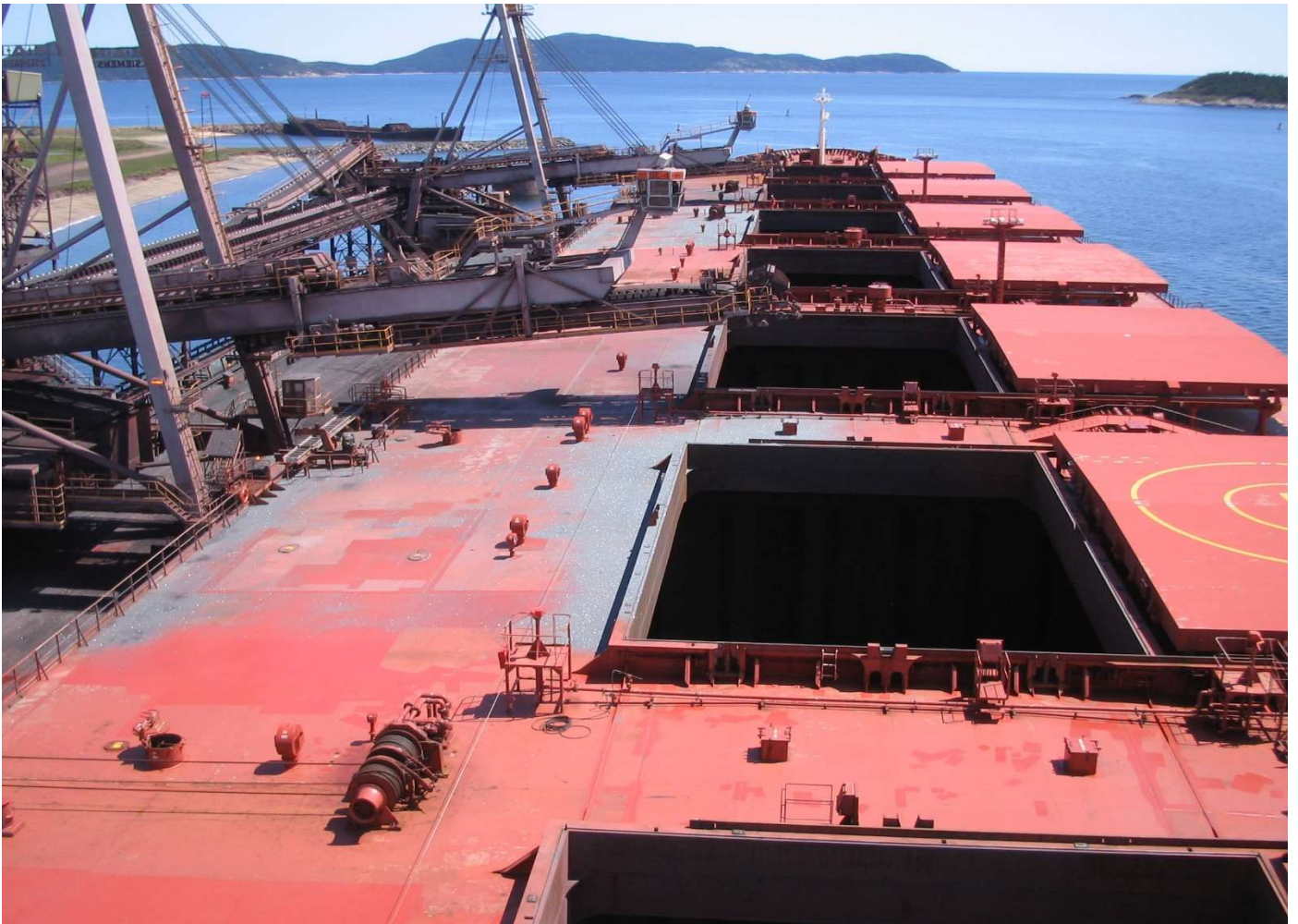

NOTICE TO SHIPS BOUND FOR SEPT-ILES IRON ORE COMPANY OF CANADA

EFFECTIVE JANUARY 01, 2023

UNTIL FURTHER NOTICE

IRON ORE COMPANY OF CANADA, MARINE SERVICES

1, RETTY STREET, SEPT-ILES, QUEBEC, CANADA

G4R 3C7

TELEPHONE NO. +1-418-968-7540 (24 Hrs)

E-MAIL ADDRESS: 00.marineservices@riotinto.com

Revision of Notice to Ships

IRON ORE COMPANY OF CANADA reserves the right, at any time or from time to time, and without notice, to revise or supplement the present Notice to Ships.

INDEX

PART ONE

SECTION		PAGE
I	General Location	5
II	Local Time	5
III	Traffic Regulations	5
IV	Arrival notification	5
V	Docking Instructions	5
VI	Working Hours	5
VII	Docking Pilot	6
VIII	Tug Service	6
IX	Supplies, Bunkers, Repairs, etc.	6
X	General Instructions for the Handling of Iron Ore	7
XI	Dock Features	8
XII	Standard Practice of The Terminal	9
XIII	Pollution & Use of Scrubbers	9
XIV	North American Emission Control	9
XV	VTS Escoumins Traffic Station and Frequency	9
XVI	Weather, Ice Report and Notice to Shipping	9
XVII	Port Facility Security (ISPS)	10
XVIII	Quarantine	10
XIX	Authorized Discharge – Cargo Residues	10
XX	Port Expenditures	11
XXI	Customs and Immigration	12
XXII	Special Conditions For Laker Vessel	13
XXIII	Applicable Laws and Regulations	13
XXIV	Appendices	13

PART TWO

APPENDICES		PAGE
1	Aids To Navigation	14
2	IOC Terminal (Photo)	16
3	IOC Port Facility (Chart)	17
4	Layout of Dock No. 1	18
5	Layout of Dock No. 2 Loaders	19
6	Layout of Dock No. 2	20
7	Standard Towing Procedure	21
8	New Line Handling Signalization	22

I GENERAL LOCATION

The city of Sept-Iles is located on the Northeast side of the Baie des Sept-Iles, a sheltered circular basin screened to seaward by seven small islands, on the North shore of the St. Lawrence River in Latitude 50°12,8'N and Longitude 066°22.5'W

II LOCAL TIME

Sept-Iles maintains Eastern Standard Time (GMT-5) from the first Sunday in November until the second Sunday in March. Eastern daylight time (GMT-4) is maintained for the balance of the year.

III TRAFFIC REGULATIONS FOR THE ST-LAWRENCE'S GULF AND RIVER

1. Eastern Canada Vessel Traffic Service Zone

The zone extends from outside of Belle Isle and Cabot Straits to 066°00'W.

In general, the regulations states that a Vessel crossing seaward boundary, either entering or leaving the zone, must report to ECAREG via any Canadian Coast Guard Radio Station. Clearance to move within the zone must be obtained from ECAREG and there are "Calling-in-points" (RAMN 2023) where a Vessel has to report.

There are also additional reports to be made in case of any defects in machinery, navigational aids, accidents, stranding, pollution, etc.

2. St. Lawrence Waterway Traffic Regulations:

The zone extends from 066°00'W to Montreal.

The regulations state that a Vessel must report to the marine traffic regulator by contacting Escoumins Traffic on VHF Channel 14 before entering Zone 1. (eg. crossing 066°00'W). The port of Sept-Iles is in Zone 1.

Once within harbour limits, Vessels must maintain a continuous radio watch Channel 14, 12 and continuous radio watch VHF 12 once alongside.

Clearance must be obtained from Escoumins Traffic 15 min prior any Vessel movement within the harbour.

IV ADVISING ARRIVAL

1. E-mail address: 00.marineservices@riotinto.com
2. Canadian Coast Guard station (VTS) Escoumins Traffic call sign "VCF", operates 24 hours / 365 days .
3. Vessels must report daily once underway for Sept-Iles.
4. Arrival notice must contain date and estimated time of arrival.
5. Vessels sailing in ballast from any port west of Les Escoumins eg. Montreal or Quebec must send ETA on departure with updated ETA later if necessary.
6. Vessels must advise expected ballast pumping time including stripping at least 24 Hrs before arrival to load Port. If any changes in ballast situation should occur after initial notice, same should be notified as soon as possible via email to Shipper's agent.
7. IOC. Marine Services office is equipped with VHF Radio sets on Channel 12.
8. Use of Channel 12 is restricted to port operations only.

V DOCKING INSTRUCTIONS

1. Vessels must notify IOC dock office 1 hour prior arrival Sept-Iles Pilot station via VHF Ch. 12 & request final berthing / anchoring instructions.
2. IOC Marine Services is set up to receive radio communications via VHF Ch 12 on a 24 hour basis / 365 days.
3. Vessels must anchor within the triangulated area as per your marine chart. Vessels may be requested to reposition from their anchorage position if it interferes with normal docking approaches and / or transshipment area.
4. Vessels arriving in ballast condition to load at dock no.# 2 are required to arrive at the loading dock within the maximum requested air draft restriction of 17.6 meters to ensure safe handling procedures.
5. Vessels must berth Port side to, unless specified otherwise from IOC Marine Services.

VI WORKING HOURS

IOC Marine Services working schedule as following:

1. Available (24 Hours)
2. Available year round (365 days)
3. No planned stoppage / closures for holidays

VII DOCKING PILOT

Except as provided otherwise in section XXII and XXIII:

1. The use of a docking pilot is compulsory for Vessels docking, shifting or sailing from IOC's docks.
2. When docking on arrival, a Docking pilot will board the Vessel inside harbour limits in area of 50°10'N and 066°24'W. Vessels will normally proceed to anchorage without Pilot assistance, but if requested, a docking Pilot can be provided taking into account that we need a 1 hour notice.
3. The docking pilot, when engaged in the operations or assisting a Vessel becomes the servant of the Vessel and the owner or master of the Vessel shall not be relieved from liabilities for any injuries, damages or loss caused by or to the Vessel, any cargo, person and/or property, including that of IOC, whether same is on board the Vessel or not, whether as a result of the docking pilot's negligence or otherwise, on the grounds that any such injuries, damages or loss occasioned by the act or default of the docking pilot or on the grounds that such Vessel was being served by the docking pilot. In addition, the owners and master of the Vessel agrees that the docking pilot and IOC shall incur no personal liability for any injuries, damages or loss to a person or property caused by said docking pilot, whether as a result of his negligence or otherwise.
4. The use of any docking pilot service shall constitute an acceptance of the terms and conditions as set forth herein regardless of, whether or not; written acceptance thereof has been given.
5. All Vessels shall provide midship starboard side gangway as appropriate for boarding / disembarking docking pilot on arrival / departure. Gangway should be set at 5 meters above water. Gangway must be well secured by adequate lashings to rails or deck.
6. All boarding equipment used for boarding or disembarking pilot must be well inspected, in good working condition and free of any obstruction, such as ice / material.

VIII TUG SERVICE

Except as provided otherwise in section XXII and XXIII:

1. Tug & pilotage service is compulsory at IOC docks. Tugs operate in accordance with the Standard Towing Conditions, as agreed between the Shipping Federation of Canada and the Eastern Canada Tug Owners Association. (See appendix p. 20).

For the application of the Standard Conditions, where IOC provides tug services directly or indirectly to a third party, the expression "TUG COMPANY" shall include IOC

2. Tugboat service as follow:
 - a. 2 Tugboats are available at all times with a 1-hour mandatory minimum notice. Tugs have an average power of 5000 HP and bollard pull of 60 tons average.
3. All communications between tugs and pilots are performed by VHF radio on channel 18A for all manoeuvres within Sept-Iles harbour.
4. Vessels will be provided with tug tow lines if required.

IX SUPPLIES, BUNKERS, REPAIRS, MEDICAL

1. No bunkering operation are permitted on IOC grounds.
2. Minor repairs can be performed at Sept-Iles.
3. Fresh water can be supplied at the approximate rate of 10 tons per hour. Hose is available at the dock but ships' crew are required for connecting and disconnecting.
4. Please note that IOC Marine Services, as Load port "Shippers" Agent, does not attend to Owners matters such as stores, CTM, medical, crew changes, etc.
Should you require any of these services and do not have an Agent, we may refer you to a local agent upon request.
5. Launch service is available on request through I.O.C. Marine Services.
6. Seamen's Centre is located at Pointe-aux-Basques dock.
7. Medical services are available in Sept-Iles, however same must be arranged via an owner's agent or local agent.
8. Small parcels (Less than 2.5 Kg) can be handled by our agency; however, they must be sent on DDP basis (All fees for shipper's account). All request for Customs clearances / Broker services will be refused. Vessel's name (Not Captain) must be written on the parcel.

X GENERAL INSTRUCTIONS FOR THE HANDLING OF IRON ORE AND THE PREPARATION OF HOLDS

1. Iron Ore Pellets:

- a. Iron Ore pellets have an average density of 2.162 MT / M³ and an average stowage factor of 0.463 M³ / MT.
- b. Before acceptance of a Vessel for loading, all cargo holds should be swept cleaned and no residues left inside. Vessels which had alumina, bauxite, salt, calcium or urea, **MUST** be wash cleaned in order to be considered acceptable for loading.
- c. IOC reserves the right to require to have Holds wash cleaned prior berthing in order to avoid possible contamination (Whatever materials cargo holds may have had prior).
- d. Holds cleanliness inspection will be done by an independent Surveyor.
- e. Please note that if Surveyor finds Cargo Holds not acceptable due to possibility of contamination, then time loss will be for Vessel's account.

2. Iron Ore Concentrate:

- a. Iron Ore concentrates have an average density of
- b. 2.74 MT / M³ and has an average stowage factor of 0.365 M³ / MT.
- c. Iron Ore Concentrates contain an average moisture content of 2.5% to 4.5%. The character of this ore is SELF DRAINING. It will retain moisture up to about 2.5%, but all moisture over and above that will drain on compaction of the material, also, if the ore is left for long periods in stockpile or in the holds of the Vessel, this drainage of moisture could generate water accumulation in the hold of the Vessel and could cause some inconveniences when discharging the cargo. For this reason, all bilge Wells should be sounded regularly and pumped out at regular intervals, so as to minimise possible water accumulation between vessel's tank top & the cargo.
- d. Iron Ore Concentrate is abrasive and could cause damages to bilge pumps. Master of Vessel should be aware that Federal Regulations require bilge wells to be covered with double layer of burlap, so as to permit a free flow of the water and retain the Iron Ore Concentrate in the holds of the Vessel.

3. Report to Port Warden:

It is the responsibility of the Master to ensure that the Vessel is in a fit state to load and to proceed as required under the Canadian Regulations adopted pursuant to Canada Shipping Act, 2001; but the Shipper is required to ensure that the Master is aware of the requirements and that flagrant violations are brought to the attention of the Port Warden in order that corrective measures may be taken, Cargo loading should cease pending the arrival of the Port warden.

4. Transport Canada - Port Warden

Certificate of readiness to load:

- a. Vessels loading full or partial cargoes of Iron Ore Concentrates must obtain a CERTIFICATE OF READINESS TO LOAD from Transport Canada authorities prior loading. (Canada Shipping Act, 2001 - Cargo, Fumigation and Tackle Regulations)

Cargo holds inspection by Transport Canada will be usually done at distance. Therefore, it is important to provide all required documentation and pictures of the holds taken at daylight to Shipper's Agent as requested from Pre-Arrival Instruction message. If all documentation and pictures presented are acceptable by Transport Canada authorities, then Port Warden will issue Certificate of Readiness to load after arrival within Port limits. If all documents and pictures presented not satisfactory to Transport Canada authorities, then Vessel will have to be inspected once alongside at daylight only. Please note that in this case, all time loss will be for Vessel's account.

- b. Bilges to be cleaned and bilges strainer plates to be covered with at least a double layer of burlap or approved equivalent arrangement in order to be concentrate tight but not watertight. Ensure to take pictures of the plates clearly indicating the pierced holes free of obstructions / material before placing the double layer of burlap.
- c. Weights on double bottoms, shear stresses and bending moments to be within permissible limits.
- d. Vessels are responsible to obtain said certificate alongside or at anchorage. The Vessel which fails to obtain a "CERTIFICATE OF READINESS TO LOAD" shall not be loaded. Time required to obtain certificate shall be on Vessel's account.

5. Transport Canada - Port Warden

Certificate of Fitness to Proceed:

Vessels loaded with a full or partial cargo of Iron Ore Concentrates must obtain a CERTIFICATE OF FITNESS TO PROCEED from Transport Canada prior departure. (Canada Shipping Act, 2001 - Cargo, Fumigation and Tackle Regulations)

XI DOCK FEATURES

1. No. 1 DOCK (Unloading or Waiting Berth):

670m dock divided into three berths. Those berths are identified on the marine charts respectively as #4, #5 and #7. The southeast (#4; Mooring or waiting berth) is 244m in length and is fendered with large truck tires mounted over the dock face. The adjoining (#5; Unloading or waiting berth) is 244m and also fendered with large truck tires. The third and last section (#7; A government berth exploited by port authority and presently closed), is 183m in length and used for general cargo. Dredged depth at mean low water is 11.10m at berth #4 and 10.0m at berth #5. Designed depth at the government berth is 7.31m.

a) No. 1 - Unloading dock (Berth #5):

The dock is fitted with a hopper for self-unloading Vessel

Unloading capacity:

- Bentonite: 200 MT/Hour
- Limestone: 2,500 MT/Hour
- Coke Breeze: 2,000 MT/Hour

VSL restrictions:

- Max Loa: 225.5m
- Max beam: 30m
- Max draft: 10.0m
- Max air draft for Geared Vessel: 16.0m

If a Vessel is exceeding these restrictions, Vessel is subject to receiver's approval and costs involved due the Vessel exceeding restrictions will be for charterers or owner's account.

Vessels have to be fitted with cranes in good order to be able to lift the loader (12 tons) in and out from the ship holds for trimming purposes and also subject to receiver's approval. Good working heaters in the Crane cabins have to be fully functional for colder seasons as window wipers also in case of precipitations.

2. No. 2 DOCK (Loading Berth):

Deepwater berth is located some 274m southeast of original dock and extends approximately 70m further into Bay. This single berth is an open cell construction with 9 parallel cribs, inset from dock face and dolphins. Both structures are fitted with mooring winches and bollards and located approximately 46m and 107m respectively from NW corner of the dock face. Two additional dolphins, also fitted with mooring winches and bollards, are situated in a line approximately 46m inside the dock face and approximately 30m and 122m from SE corner of dock. Dolphins are joined to main dock structure by catwalks. Total effective mooring length is approx. 488m. Cribs are fendered to waterline with double sets of extra-large truck tires. Dredged depth is approximately 17.8meters at mean low water. Dock is fitted with two travelling shuttle boom loaders with 233m of available travel, and a maximum design capacity of 7500 MTPH per loader.

Dock No. 2 is fitted with bollards spaced at 30m centres.

Water density alongside:

May to October varies from 1.018 to 1.022

November to April varies from 1.022 to 1.025

Note: Actual density determined by C/O and independent surveyor during Initial draft survey.

VSL restrictions:

- Max LOA: 330m.
- Max beam: 54m.
- Max air draft to top of hatch cover: 17.60m,
- Max recommended sailing draft: 17,10m + tide.
- Depth = 17.70 m at zero on the chart.

“Depth of water and maximum sailing draft restrictions at IOC Docks no. 1 and no 2 may be subject to change without prior notice.

Latest conditions can be provided upon request from Rio Tinto- IOC Marine Services.”

XIV NORTH AMERICAN EMISSION CONTROL

Transport Canada advises all vessels inbound for east coast Canadian ports, that they are required to use fuel that has a sulphur content not exceeding 0.1%, (effective January 1st, 2015) when within the North American emission area (na-eca)

Vessels when voyaging in accordance with their voyage plan, that have not been able to obtain compliant fuel meeting the standards of the na-eca, are required to notify the minister of transport before entering Canada’s na-eca.

XII STANDARD PRACTICE OF THE TERMINAL

Except as provided otherwise in section XXII and XXIII:

1. Vessels will be loaded in regular turn of arrival, subject to cargo availability and providing they arrived with 2 holds to commence loading readily open upon berthing. The loading time should be calculated at the average rate of 10,000 mt per hour with two shore loaders & 5,000 mt per hour with 1 shore loader at dock No. 2.
2. Final Loading plans should be emailed to the terminal prior berthing for final validation.
3. ORE-OIL (OBO) carriers having discharged petroleum products at last port must advise this in first ETA. If gas-free certificate has not been already granted by independent chemist, arrangements will be made to have chemist attending. The arrangement for such service implies no liability whatsoever on the part of IOC Marine Services and all expenses to be for vessel's account.
4. Vessels will have 1 hour to sail from the dock upon completion of loading / unloading operations, if more time is required to secure for sea, same could be perform within harbour limits. If any delays occur due to crew members missing, etc., Vessel will vacate the dock and all matters will be handled from the anchorage area.
5. Any Vessel which fails or refuses to vacate the berth when required by IOC Terminal shall be assessed, in addition to any other charges due hereunder, an automatic charge of \$1,600 per hour or any part thereof after vacating notice has been given in writing to the owner, manager, agent, master, mate, operator or charterer of the Vessel. This charge shall be paid promptly and it is accepted that it accurately represents a minimum estimate of damages to IOC because of refusal or failure of the Vessel to vacate. This payment shall not constitute a waiver on the part of IOC to claim greater actual damages that may be sustained as a result of the vessel's failure to vacate
6. Vessel’s gangway should be kept at same level as shore installation.

Watchman should be aware of loading / unloading, de-ballasting / ballasting and stage of tide in order to maintain same level.

If the shore gangway is damaged or lost due to none compliance of the above, the repair or recovery cost will be charged on vessel’s account.

Should shore personnel have to go on board and gangway is not secure, loading will stop immediately and delay will be held against the ship.

XV ESCOUMINS TRAFFIC STATION MCTS

(VTS) CALL SIGN “VCF” (418) 233-2194

VHF	<u>Calling Frequency</u>	156.8 MHz CH.16
		156.7 MHz CH.14
VHF	<u>Working Frequency</u>	
	Transmitting	161.9 MHz CH.26
	Receiving	157.3 MHz CH.26
		156.3 MHz CH.06

XVI WEATHER, ICE REPORTS, AND NOTICE TO SHIPPING

A continuous marine broadcast service is available on VHF CH 21B. Recorded information is updated continuously 24 hours per day.

XIII POLLUTION & USE OF SCRUBBERS

The discharge of oil, chemicals and garbage into Canadian water is prohibited by strictly enforced regulations which provide for heavy penalties on summary conviction. The regulations require that any pollution be reported immediately to the nearest Transport Canada inspection office, or to the nearest VTS station.

As per Port of Sept-Îles regulations, the use of ‘Open Loop Scrubbers’ is strictly prohibited within Harbour.

XVII PORT FACILITY SECURITY (ISPS)

For the purpose of ISPS any visitors or supplier must contact & notify IOC Marine Services in writing beforehand providing reason of visit, name of visitor, date & time expected for same.

Shore gangway will be rigged & attached to ship's gangway in an L configuration at no expense to the vessel. This gangway is to be protected by the vessel at all times. If a situation exists or becomes evident compromising the safety or integrity of same, the vessel must inform IOC dock office to have the gangway removed or rigged in a different configuration immediately. Failure to notify the terminal and/or agent accordingly, will result in the vessel/Owner being liable to all damages incurred. Vessel must rig a safety net under the gangway. Such net shall be installed as to catch anyone that might fall off while embarking or disembarking the vessel.

There must be a passage on ship's decks free of hazards, so as to permit Terminal representative & port officials to carry their duties safely.

During the cold weather season, all accesses, including hatch covers, must be kept free of ice.

Any failure to comply with the above rules may cause the shore personnel to refuse to board, and the cost of any delay incurred, while the ship's crew rectifies the situation, will be charged against the vessel.

The Company's policy regarding security of its privately owned dock area in regard to crew member going ashore is as follow: In order to avoid the access of unauthorized persons to the area or on board vessels, all crew member going ashore must request a taxi via IOC dock office VHF ch 12 or use the seamen centre shuttle service as per their regular schedule & report to the security gate for the purpose of identity going out & on their return.

Access to the wharf is strictly forbidden to private vehicles driving sailors back to their ship. The only vehicles authorized to drive to the wharf are taxis, the seamen centre shuttle, or any other rental vehicle having been authorized by the terminal.

XVIII QUARANTINE

1. Ships calling Canadian ports are no longer required to follow Radio Pratique, Free Pratique is now granted once vessel clears with ECAREG unless

- There is a condition of health irregularity aboard or,
- If the ship has called at an infected port during this same voyage.

2. Only ships to which any of the above conditions apply, should send report to IOC marine services giving details regarding health conditions aboard, so appropriate action can be taken immediately

XIX AUTHORIZED DISCHARGE - CARGO RESIDUES

1. (f) for a ship in the St. Lawrence River west of Les Escoumins, the cargo residues are not cargo sweepings and the ship is en route;

(g) for a ship in the inland Waters of Canada in the St. Lawrence River east of Les Escoumins, the ship is en route and the cargo residues are discharged from it at a distance of more than 6 nautical miles from shore; and

(h) For a ship in the St. Lawrence River or Gulf of St. Lawrence that is not in the inland waters of Canada, the ship is en route and the cargo residues are discharged from it at a distance of more than 12 nautical miles from shore.

2. For the purposes of paragraphs (1) (f) to (h), the authorized discharge of cargo residues is restricted to alumina, bauxite, bentonite, cement, chrome ore, clay, dolomite, ferromanganese, gypsum, ilmenite, iron ore, iron ore concentrate, lead ore concentrate, limestone, manganese ore, manganese concentrate, nepheline syenite, perlite, quartz, salt, sand, talc, urea, vermiculite and zinc ore concentrate.

3. For the purposes of this section, the master of the ship shall ensure that no discharge of cargo residues is made if, through visual observation, a marine mammal is within 0.5 nautical miles of the ship.

All discharges into harbours and ports are prohibited.

XX PORT EXPENDITURES

1. The below port fees will apply to all vessels, as per their SDWT, loading ore at I.O.C.'s docks at Sept-Iles.

Port fees include agency, tugs (two (2) tugboats for berthing and two (2) for sailing), docking pilot expense, linesmen, customs expense, sundries, etc.

**SCALE OF PORT FEES FOR VESSEL AT DOCK #2
(SUNDRIES NOT INCLUDED)**

		<u>DEADWEIGHT</u>	<u>FEES 2023</u>
LAKERS	Up To	36,000	\$ 12,016
	36,001	40,000	\$ 16,109
OCEANS	Up to	10,000	\$ 24,025
	10,001	20,000	\$ 30,272
	20,001	30,000	\$ 38,143
	30,001	36,000	\$ 47,966
	36,001	40,000	\$ 52,739
	40,001	50,000	\$ 62,835
	50,001	60,000	\$ 72,697
	60,001	70,000	\$ 82,297
	70,001	80,000	\$ 89,792
	80,001	90,000	\$ 97,259
	90,001	100,000	\$ 104,756
	100,001	110,000	\$ 111,940
	110,001	120,000	\$ 118,796
	120,001	130,000	\$ 125,908
	130,001	140,000	\$ 132,954
	140,001	150,000	\$ 140,122
	150,001	160,000	\$ 147,209
	160,001	170,000	\$ 154,559
	170,001	180,000	\$ 161,718
	180,001	190,000	\$ 167,908
190,001	200,000	\$ 174,127	
200,001	210,000	\$ 177,737	
210,001	220,000	\$ 172,389	
220,001	230,000	\$ 176,365	
230,001	240,000	\$ 181,491	
240,001	250,000	\$ 186,136	
250,001	260,000	\$ 192,186	
260,001	270,000	\$ 198,445	

1. Government / Crown Fees:

- a) Coast Guard Marine Navigation Service Fees: \$0.1630 per metric tons of cargo (Max \$8,150.00)
- b) Agriculture Manifest Assessment: \$41.62 (Vessels arriving from sea only)

- c) Coast Guard ice breaking service fees:
Basic rate: \$3,334.75 per transit

There will be a maximum of eight chargeable transits per ship per ice season commencing December 21st and ending April 15th. This seasonal cap is not transferable between vessels. Additionally, there will be a maximum of three chargeable transits per 30 day period. This seasonal cap is not transferable between vessels.

Ice Breaking Service Fees - Discounts:

There is a discount for superior ice strengthening. It is defined as matching the requirements for Canada vessel type A, B, C, D or Artic Class (or internationally recognized equivalents) see below scale.

Common International Ice Strengthening Equivalents

Discount	Canada	Lloyd's Register	Baltic (Det Norske Veritas)	Germanischer Lloyd
35%	Type A	1* 1-A Super	A* 1-A*	E-4
35%	Type B	1 1-A	A 1-A	E-3
25%	Type C	2 1-B	B 1-B	E-2
15%	Type D	3 1-C	C 1-C	E-1

- 2. ISPS fee will be charged to any vessel calling our port facility on a basis of 63\$ per hour once alongside. This ISPS fee is to cover for the high cost of maintaining the required level of ISPS.
- 3. The Port of Sept-Iles operates under the authority of Canada Ports Corporation and the dues are (\$0.1029) per GRT for all Canadian ships' entry and (\$0.1029) per GRT for all other ships per entry.
- 4. Tug service provided in port fees does not include services of salvage nature.
- 5. All ships' Owners or Principals will be required to transfer 100% of Proforma Disbursement Account (PDA) funds to IOC in advance to cover port costs as per above scale of fees. PDA must be received prior to vessel tendering its Notice of Readiness and berthing.
- 6. Interest of 1.5% per month or 18% per annum may be charged on overdue accounts for supplementary disbursements or failure to remit advance funds.
- 7. Please note that IOC Marine Services, as Loadport "Shippers" Agent, does not attend to Owners matters such as stores, CTM, medical, crew changes, etc.

Should you require any of these services and do not have an Agent, we may refer you to one upon request.
- 8. Fresh Water is available & will be charged as follow:

Alongside: \$175.00 service charge + \$10.00 per M/T

9. One (1) Extra Tug(s) may be requested by Pilot / IOC for vessel safety, berth safety or weather reason (I.E Strong Winds, High swell or Dense Fog).

All vessels sailing with foreign flag and SDWT greater than 36,000 MT will be sailed from IOC docks #1 using two (2) tugboats.

While Port Fees for Dock #1 include two (2) tugboats for berthing and one (1) for sailing, extra tug fees have been issued in order to increase the safety level at our installations and eliminate unnecessary risk for all stakeholders.

Extra cost incurred for the second tugboat at sailing will be based off vessel's SDWT as follows:

SCALE OF EXTRA TUG SERVICES FEES			
	<u>DEADWEIGHT</u>		<u>FEES 2022</u>
LAKERS	Up To	40,000	\$ 4,015
OCEANS	Up to	10,000	\$ 4,015
		10,001	\$ 4,253
		20,001	\$ 4,505
		30,001	\$ 4,773
		40,001	\$ 5,056
		50,001	\$ 5,356
		60,001	\$ 5,675
		70,001	\$ 6,012
		80,001	\$ 6,368
		90,001	\$ 6,747
		100,001	\$ 7,147
		110,001	\$ 7,571
		120,001	\$ 8,021
		130,001	\$ 8,497
		140,001	\$ 9,002
		150,001	\$ 9,536
		160,001	\$ 10,102
		170,001	\$ 10,702
		180,001	\$ 11,337
		190,001	\$ 12,011
		200,001	\$ 12,723
		210,001	\$ 13,478
		220,001	\$ 14,279
		230,001	\$ 15,126
		240,001	\$ 16,025
		250,001	\$ 16,971
		260,001	\$ 17,973

XXI CUSTOMS AND IMMIGRATION

1. Ships arriving from a foreign port may be boarded by customs and immigration officers. SHIP'S PERSONNEL ARE NOT ALLOWED ASHORE UNTIL PERMISSION IS GRANTED FROM ABOVE OFFICERS OR AGENCY.
2. Customs requires 96 hours prior vessel arrival, crew list and vessel pre-arrival notification. Please send us by email: 00.marineservices@riotinto.com
3. The following inward papers are to be completed prior to arrival and presented to custom officer on boarding:

Immigration	IMM-200	Crew List
Customs	A-6	Report Inward
Customs	Y-14	Crew Declaration
Customs	E-1	Ship's Stores
		Last Port Clearance

4. Designation and dates of expiry of ship certificates is required for all custom declaration: IOPP, Load Line, International Tonnage, Safety Equipment, Safety Radio, Safety Construction and Sanitation.
5. Arrangements have been made so that loading can commence before customs entry has been completed, and customs outward papers will be completed so as not to interfere with immediate departure after completion of loading.
6. By Canadian Customs regulation, each crewmember is allowed to retain in his possession for his personal consumption. For tobacco product: 200 cigarettes; and 50 cigars; and 200 grams of manufactured tobacco; and 200 tobacco sticks. For alcohol product: 1.5 L. of wine; or 1.14 L. of hard liquor; or 8.5 L. of beer. All quantities must be declared on Crew Declaration form Y-14 along with all personal effects such as radios, cameras, laptop computer, binoculars etc., including serial numbers of each such item.
7. Concerning Importation / Exportation of Cannabis:

If you are entering Canada from another country, remember: if you have cannabis with you in any form, you must declare it to the Canada Border Services Agency. Not declaring cannabis in your possession at the Canadian border could also lead to arrest and prosecution.

If you are leaving Canada, remember, you may not take cannabis out of the country either. You may be subject to criminal charges if you attempt to travel to other countries with any amount of cannabis in your possession.

XXII SPECIAL CONDITIONS FOR LAKER VESSELS

Notwithstanding sections VII and VIII hereof, a tug is compulsory for laker vessels. However, ships shall comply with the following conditions:

1. Vessels will be loaded in regular turn of ships' arrival at Sept-Iles if they present with starting hatches open and do not have ballast pumping time which will exceed the average. The loading rate will be from 4,500 to 9,000 metric tons per hour. A ship which has berthed at the loading dock and is unable to receive cargo or is found to have a de-ballasting rate / time, which in the opinion of IOC Terminal, will not permit loading at maximum rate, may be ordered off the dock and moved to anchorage until it is in a condition to accept loading at maximum speed.

In such a case the ship will then be returned to the ore loading berth in turn, following resubmission of Notice of Readiness. All moves, delays and expenditures to be at ship's expense. IOC dock terminal management shall be the final arbitrator in case of a dispute.

2. The vessel will be solely responsible for injury, damage or loss occasioned by her to any person and/or property, including that of IOC, during the docking, shifting and/or undocking operations. Such responsibility shall include, without restricting the generality of the foregoing, the loss of profits incurred by IOC for being deprived in whole or in part of the use of the docking facilities in Sept-Iles whether by reason of physical damage to the wharf or the blocking of the access to the facilities or otherwise.
3. The vessel shall provide IOC with a comprehensive general liability insurance, or the equivalent thereof, for body injury and/or death or damage to property, including wreck removal, for a limit of not less than \$5,000,000 per occurrence, written on an inclusive basis. A certificate of the policy evidencing such insurance shall be delivered to IOC, at least thirty (30) days prior to the use of docking facilities. The policy shall be affected in a form and with insurer satisfactory to IOC. The policy shall name Iron Ore Company of Canada as an additional insured, as its interest may appear.
4. IOC, its agents, employees and/or subcontractors shall not be responsible for any damage, injury or loss of any nature whatsoever, caused (including negligence) in connection with the docking, shifting and/or undocking operations provided, however, that the above condition should not apply to damage, injury or loss to IOC's property or to damages for personal injury to or loss of life of employees of IOC and/or its agents, and/or subcontractor unless such loss or damage or injury or loss of life shall have been caused or contributed by the fault or negligence of the ship, ship owner, its agents or employees.
5. For all Lakers with SDWT less than 36,000 MT, tugboat assistance for berthing is compulsory, shifting or sailing without the assistance of tugs and pilot shall be made at the sole risk and responsibility of the vessel. The vessel shall indemnify and exclude IOC for all claims, actions or demands whatsoever for damage, injury or loss of any nature arising in connection with any act or omission of whatever nature, including but not limited to negligence of vessels, her agents or employees and of IOC, its agents and/or employees and/or subcontractors during berthing, shifting

and/or sailing operations, provided that the above conditions shall not apply to loss of or damage to IOC's property or for personal injury or loss of life of employees of IOC and/or its agents and/or subcontractors, unless such loss or damage or injury or loss of life has been caused by the sole fault or negligence of IOC, its agents, employees or subcontractors.

6. Any Vessel which fails or refuses to vacate the berth when required by IOC Terminal shall be assessed, in addition to any other charges due hereunder, an automatic charge of \$1,600 per hour or any part thereof after vacating notice has been given in writing to the owner, manager, agent, master, mate, operator or charterer of the ship. This charge shall be paid promptly and it is accepted that it accurately represents a minimum estimate of damages to I.O.C. because of refusal or failure of the ship to vacate. This payment shall not constitute a waiver on the part of I.O.C. to claim greater actual damages that may be sustained as a result of the vessel's failure to vacate.
7. IOC Terminal, through the agency (IOC Marine Services), shall have the right, authority and privilege to compel the removal of the ship, by any lawful means, at the ship's own risk and expense and shall not be liable for any damages, delay or other expenses, including legal costs, arising from the act of removal of the ship, by whosoever incurred.
8. A standby charge of \$1,600 per hour will be assessed against any ship causing delay of ore loading alongside berth when such delay is caused by the ship not complying with Port regulations and requirements.
9. Notwithstanding the above, IOC shall have the right to refuse, at its sole discretion, to which the ship hereby agrees to submit, and for any reasons whatsoever, the docking, shifting and/or undocking of a Laker vessel without the assistance of tugs and pilots.
10. All other terms and conditions as per the general rules and conditions of the present Notice to Ship.

XXIII APPLICABLE LAWS AND REGULATIONS

Masters of vessels should acquaint themselves with all applicable laws and regulations in force in Canada. Furthermore, vessels should keep readily available onboard copy of all applicable regulation in example ISMBC code, SOLAS, Notice to Mariners, applicable paper marine charts unless vessel equipped with approved precision navigation system.

The present document contains information in addition to the "Practice and Procedures" published by the Sept-Iles Port Authority. These procedures are to be followed by all vessels entering, berthed, departing manoeuvring, or at anchor in the waters of the Port of Sept-Iles.

XXIV APPENDICES

It should be noted however that I.O.C. Marine Services does not guarantee the accuracy of the information provided in the said appendices. These appendices are for the sole purpose of informing the reader and do not reflect necessarily the current status of the regulation or practice referred to therein and do not replace any aids to navigation, notice to shipping or charts that the ship is bound to carry as per the applicable laws and regulations. It is

the master's duty and sole responsibility to ensure that he has availability to review an updated version of the information provided in the appendices.

APPENDICES

1. Aids To Navigation (As Listed in Canadian Government Publication)

Name	Latitude North	Longitude West	Light Characteristic
Ile du Corossol	50°05'20.2"	066°22'36.9"	On Island Fl W. 2.5s. 12M
Iles Grande Basque	50°09'10.4"	066°22'38.6"	On W. Extremity of Island Fl W. 6.0s. 7M
Pointe au Corbeau	50°09'03.0"	066°25'29.3"	On Point Fl G. 6.0s. 6M
Pointe à la Marmite - Light Buoy D11	50°10'17.2"	066°25'45.9"	North of Point Fl G. 4.0s.
Basque Est - Light Buoy BASQE	50°10'55.3"	066°21'43.7"	Fl (2+1) G. 6.0s.
Pointe aux Basques - Light Buoy D4	50°11'02.4"	066°21'50.3"	Fl R. 4.0s.
Récif du Basque - North Light Buoy D7	50°11'00.7"	066°22'15.2"	Fl G. 4.0s.
Récif du Basque - Light and Bell Buoy D6	50°10'52.2"	066°21'57.9"	Off West Limit of Reef Fl R. 4.0s.
Basque Ouest - Light Buoy BASQO	50°10'47.9"	066°22'36.3"	Fl (2+1) R. 6.0s.
Iron Ore Company of Canada (Privately Maintained) - Dock #2 Range Lights	50°11'20.3"	066°22'14.8"	On a Hangar on Dock #2 Iso Y. 2.0s.
	122°44'	495.8 m From Front	North of Pointe aux Basques Iso Y. 2.0s.
- Dock #1 Range Lights	50°11'41.8"	066°22'35.3"	Iso G. 2.0s.
	098°29'	280.2 m From Front	Iso G. 2.0s.
Sept-Iles Oil Tanker Dock	50°11'47.4"	066°22'55.4"	On Dolphin. Flash alternately Iso W. 6.0s. 9M Iso R. 2.0s. Iso R. 2.0s.
Terminal des Croisières	50°11'50.6"	066°23'03.9"	West End of Dolphin Iso R. 2.0s. 2M
Terminal des Croisières	50°11'50.6"	066°22'48.7"	East End of Duc d'Albe, sec. 12 Iso W. 2.0s.
Havre de Pêche Sept-Iles	50°11'56.1"	066°23'00.4"	On end of Breakwater Iso G. 2.0s. 3M
Marina Sept-Iles Entrance	50°12'04.6"	066°23'10.1"	On end of Breakwater Iso Bu. 2.0s.
Marina Sept-Iles West Breakwater	50°12'11.7"	066°23'17.4"	Fixed W.

N.B. All Aids to Navigation are Subject to Change

APPENDICES

1. Aids To Navigation (As Listed in Canadian Government Publication)

Name	Latitude North	Longitude West	Light Characteristic
Sept-Iles Wharf	50°12'21.6"	066°23'32.7"	On Wharf Extension Iso G. 2.0s. 6M
Pointe Noire - Light Buoy D15	50°09'47.2"	066°27'23.0"	Q G. 1.0s
Pointe Noire Wharf Range	50°09'55.3" 179°59'	066°28'55.55" 173.3m From Front	Iso Y. 2.0s. Iso Y. 2.0s.
Pointe Noire Ore Terminal West	50°09'55.4"	066°29'10.1"	West End of Pointe Noire Wharf Fl R. 4.0s. 6M
Pointe Noire, Anse-du-Portage Ste-Marguerite. Sector Light	50°09'47.1"	066°29'12.3"	Fixed R. Al W. RW G. Al GW
La Relance Railway Ferry Wharf	50°09'39.1"	066°27'37.4"	NE End of Dolphin Iso Bu. 2.0s.
La Relance Wharf Range	50°09'33.9" 192°42'	066°27'37.4" 272m Front Front	Iso R. 2.0s. Iso R. 2.0s.
Sept-Iles, Multi-User Wharf	50°10'05.9"	066°28'15.7"	Section 35. West End Iso R. 1.0s.
Sept-Iles, Multi-User Wharf	50°10'01.5"	066°27'56.4"	Section 35. East End Iso G. 1.0s.
Pointe Noire Ore Terminal West - Light Buoy D20	50°10'06.2"	066°29'27.9"	NW of Wharf Fl R. 4.0s.
West Rocks (Ilets Dequen)	50°07'16.3"	066°25'58.1"	At West Rocks Fl R. 6.0s. 6M
Pointe à la Chasse	50°01'05.4"	066°27'07.9"	On Point Fl W. 6.0s. 8M

N.B. All Aids to Navigation are Subject to Change

IOC TERMINAL

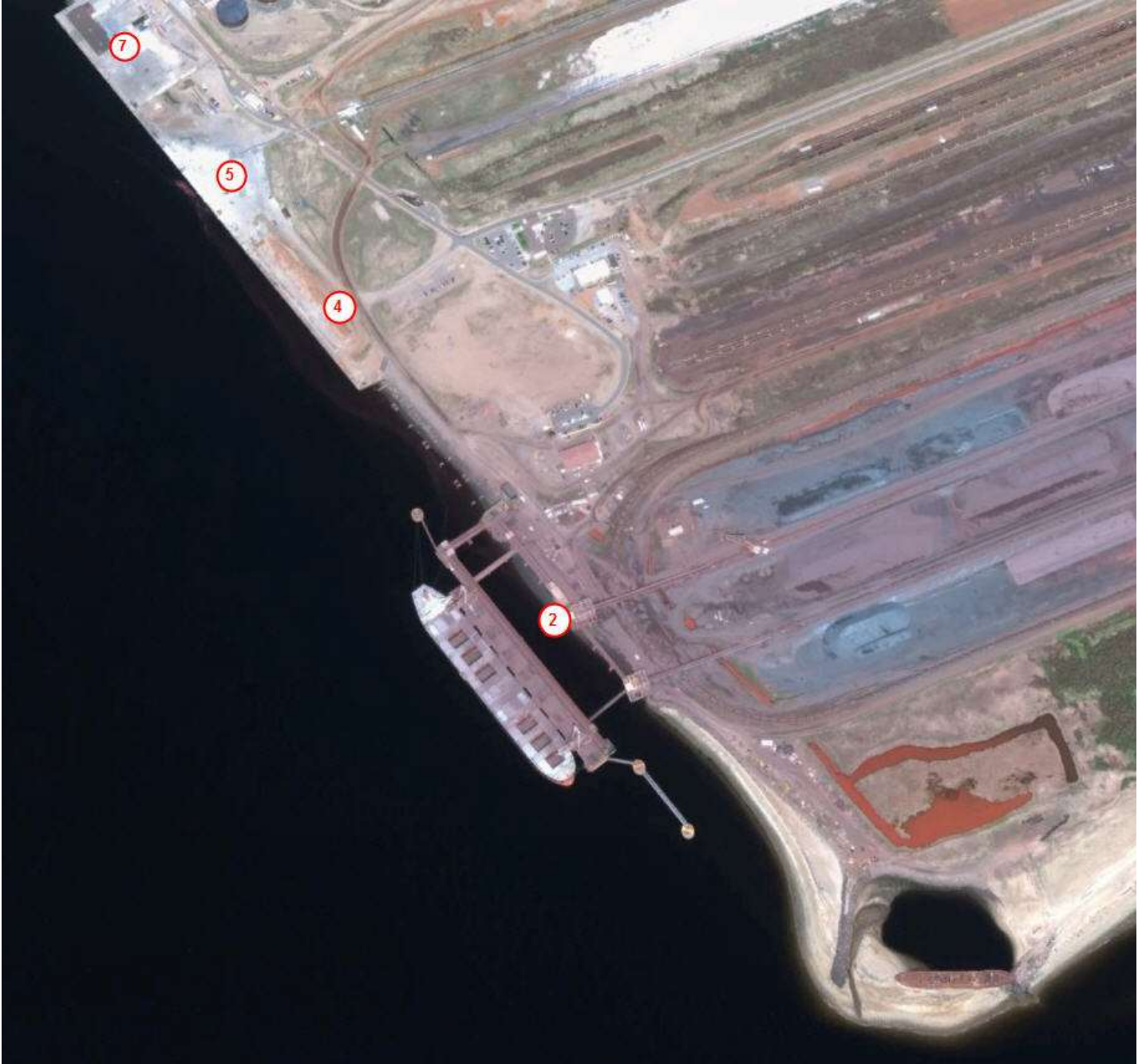

IOC PORT FACILITY

From Sept-Iles Harbour Marine Chart (1220)

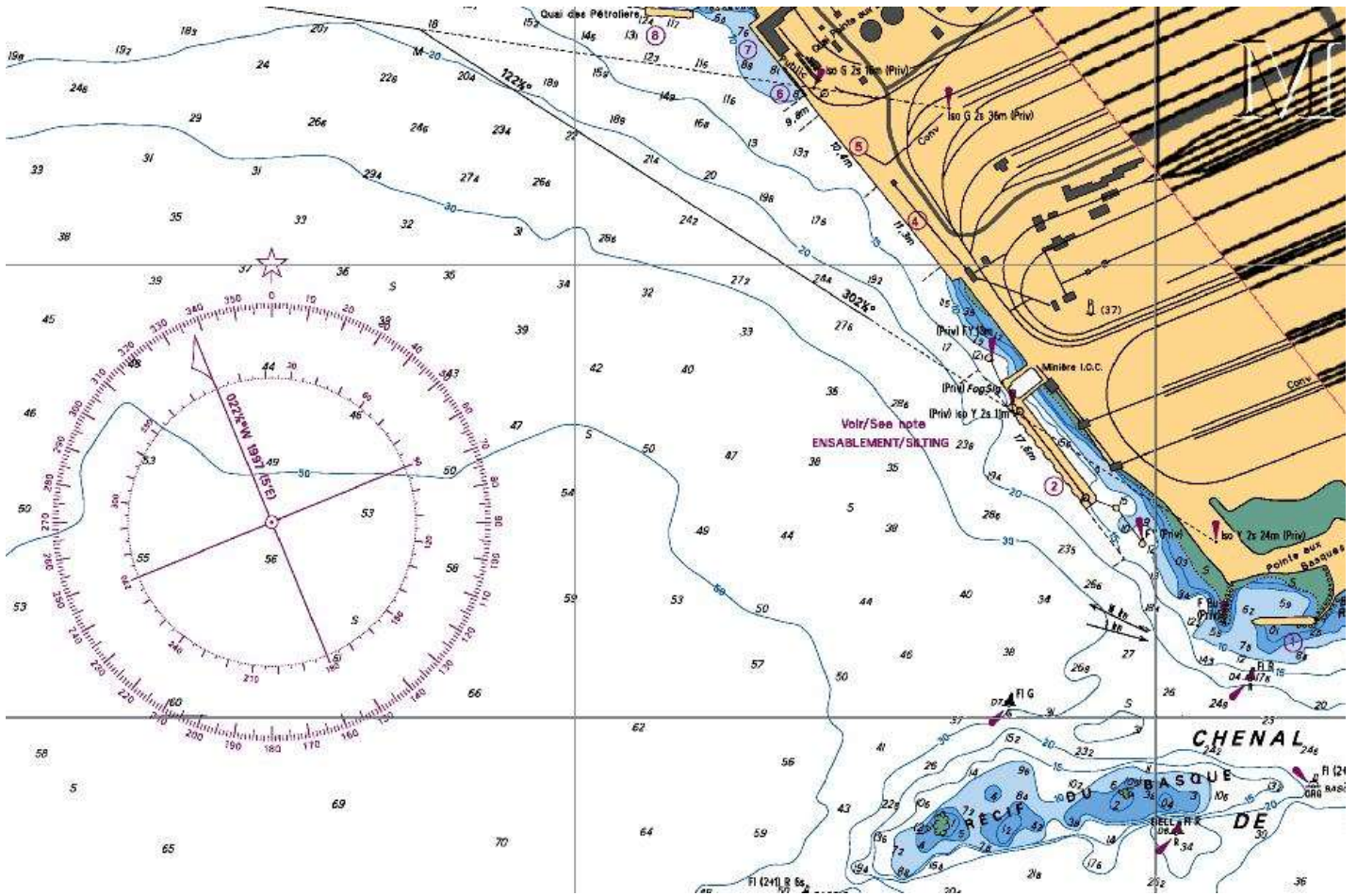

LAYOUT OF IOC DOCK No. 1 (4&5)

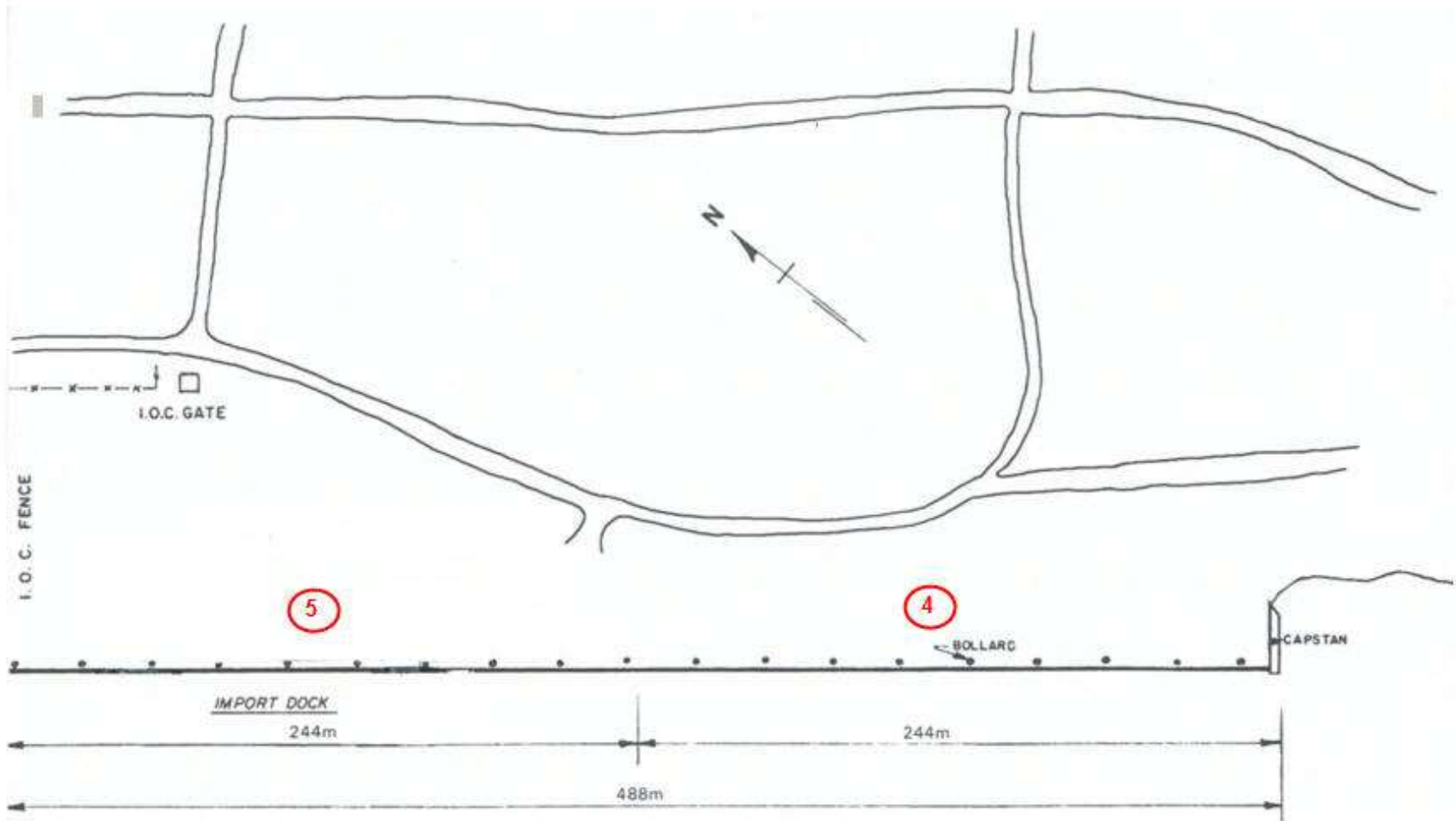

LAYOUT OF DOCK No. 2 LOADERS

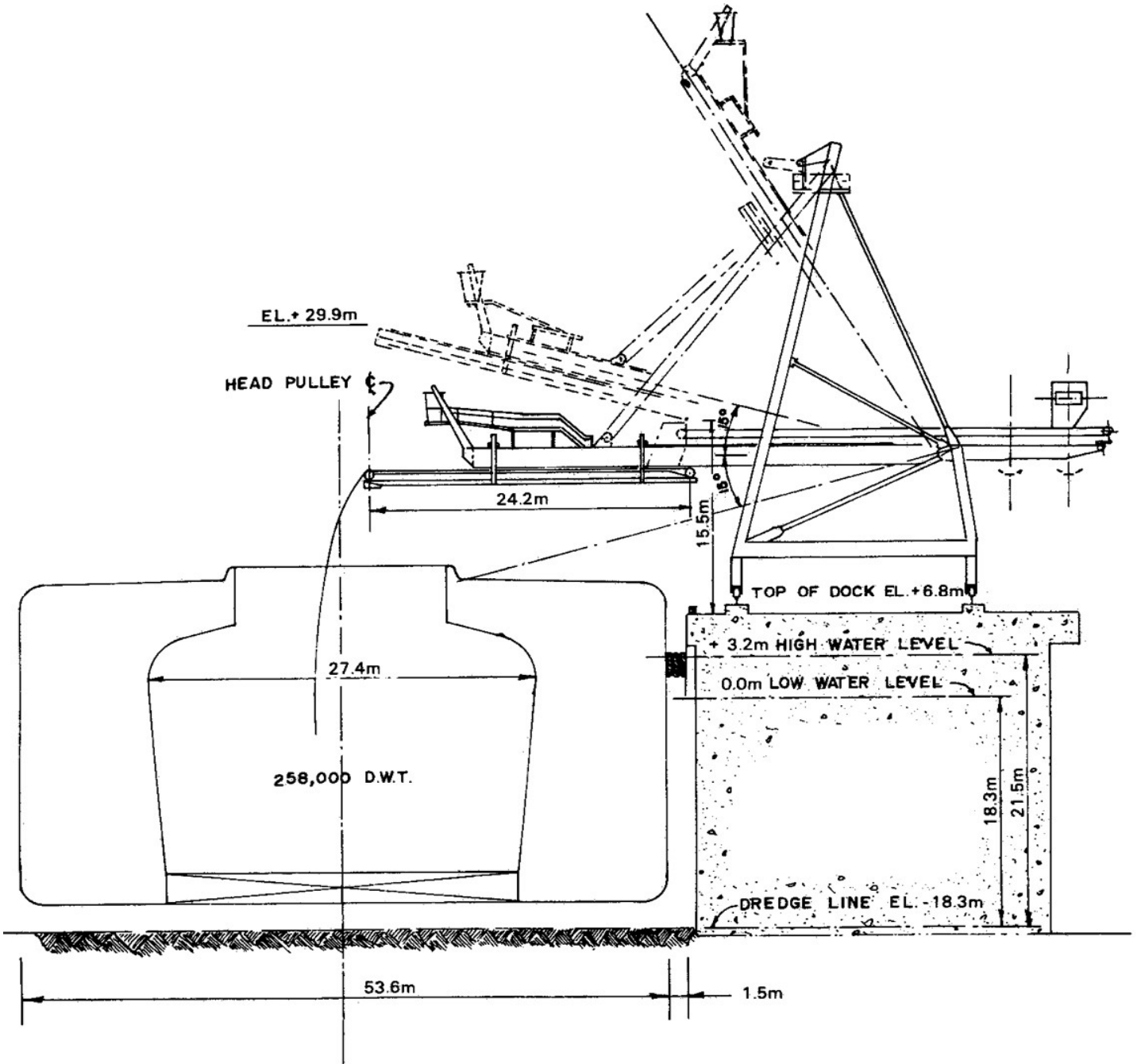

NUMBER 2 DOCK

LAYOUT OF DOCK No. 2

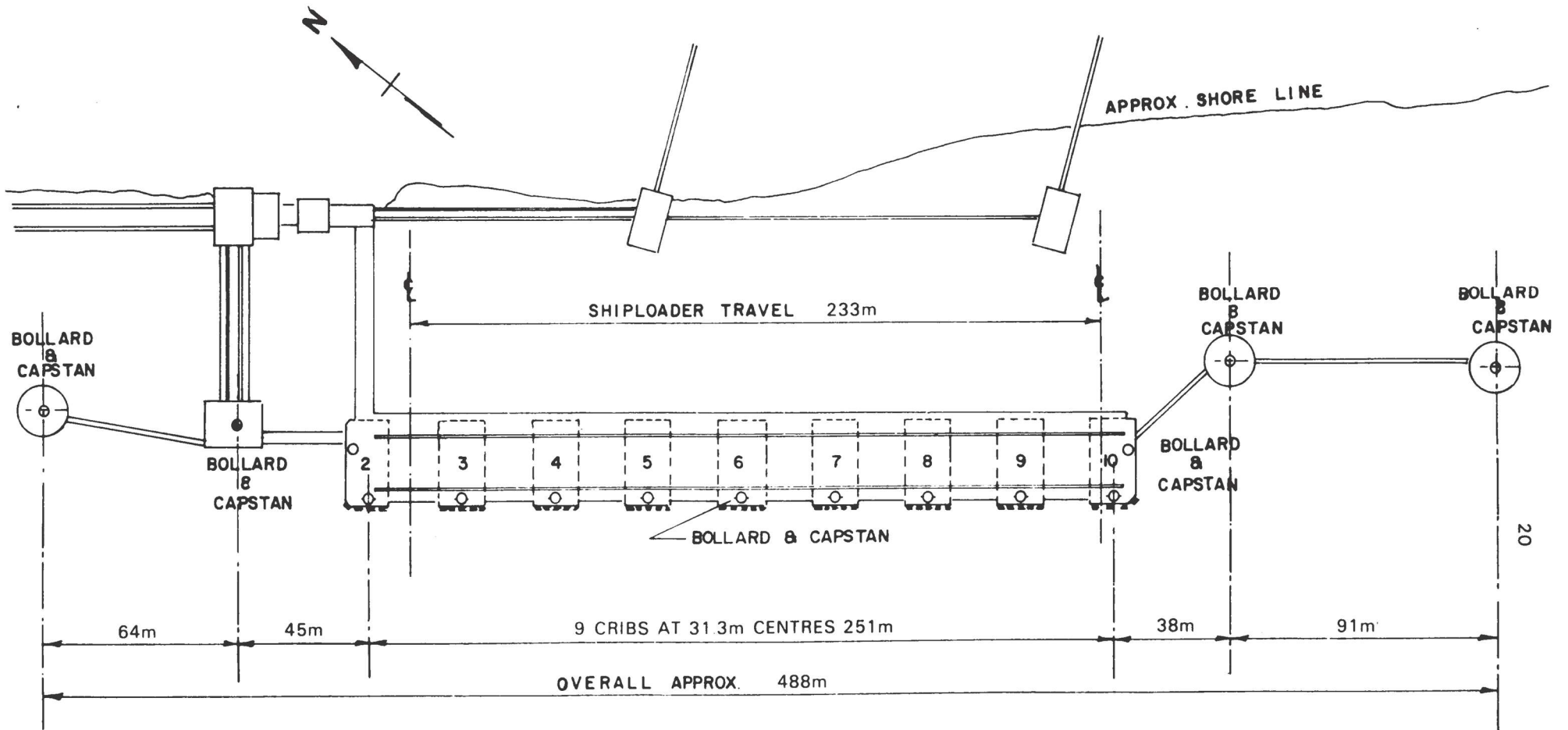

EASTERN CANADIAN TUG OWNER'S ASSOCIATION

STANDARD TOWING CONDITIONS

1. Tug Company will not be responsible for any delay in supplying tug service arising from any cause whatsoever or for any loss, damages or injuries which may be sustained in consequence thereof by the owners, charterers or operators or any vessel or craft or by any other persons interested therein.
2. Tug services will be supplied upon the condition that all towing, moving, shifting, docking, undocking or other handling of a vessel or craft of any character by a tug or tugs owned or employed by the Tug Company is done at the sole risk of such vessel or craft and of the owners, charterers or operators thereof, and that the Master and crew of such tug or tugs used in the said services and the tug themselves together with the Tug Company become the servants of and identified with such vessel or craft and their owners, and that the Tug Company undertakes only to provide motive power.
3. Neither the tug or tugs, nor the Tug Company will be responsible for the acts, negligence, gross or otherwise, of the Master or crew of such tug or tugs, or any of their servants or agents or else whosoever, nor for any damages, personal injuries or loss of life, losses, delays, cost expenses and infringement of rights from whatsoever cause arising, including unseaworthiness of the tug or tugs used in the said services, provided due diligence has been exercised by the Tug Company to make the tug or tugs seaworthy, as well as any latent defect in the hull, machinery or equipment of the said tug or tugs, that may occur either to such vessel or craft, or property or persons on board thereof, or to any other ship or vessel or to any person or property on board thereof, or to other property of any kind whether fixed or moveable or to any other person not on board the vessel or craft to which the tug service is supplied, and the Tug Company as well as the Master of the tug or tugs engaged in such services and their crew shall be held harmless and indemnified by the Hirer against all such damages, personal injuries or loss of life, losses, delays, costs, expenses and infringement of rights, and against all claims in respect thereof.
4. Such exemption from liability shall apply regardless of whether such vessel or craft assists in the services with its own steam or power or in any other way, and irrespective of whether any employee of the tug Company or the Master or any of the crew of such tug or tugs is at the time of said services on board of such vessel or craft, or in command thereof.
5. The foregoing conditions shall apply to any damages, personal injuries or loss of life, losses, costs expenses and infringement of rights from whatsoever cause arising, including unseaworthiness or any latent defect in the hull, machinery or equipment of the said tug or tugs, that may occur to the vessel or craft requiring the tug or tugs or to any other vessel or craft, or to any person not on board the vessel or craft to which the tug service is supplied, which such tug or tugs is or are in attendance upon or fast to or engaged in any manoeuvre for the purpose of making fast to or disengaging from or proceeding clear from the vessel or craft requiring the tug or tugs, provided however that the said conditions shall not apply to loss of or damage to the tug or tugs, or to property on board the tug or tugs or to damages for personal injuries or the loss of life of members of the crews of the tug or tugs or persons on board thereof, unless such loss or damage or such damages for personal injuries or loss of life shall have been caused or contributed to by the fault or negligence of the vessel or craft requiring the tug or tugs.
6. Any service of whatsoever nature to be performed by the tug or the Tug Company providing the service other than towing shall be deemed to cover the period commencing when the tug is placed physically at the disposal of whosoever has applied for the service on behalf of the vessel to whom the service will be rendered and shall continue until the employment for which the tug has been engaged is ended. If the service is to be ended at or off a vessel the period of service shall end when the tug is safely clear of the vessel or, if it is to be ended elsewhere, then when any persons, baggage, goods, mails, species, ship or engine parts or gear or articles of whatsoever description, have been landed or discharged from the tug and/or the service for which the tug has been required is ended.
7. Wherever the service of the tug or tugs is to be performed, these conditions will be construed and enforced in accordance with the applicable laws of Canada where the principal office of the Tug Company supplying the service is located.

NEW LINE HANDLING SIGNALIZATION

NEW LINE HANDLING SIGNALIZATION

ON THE MOORING DOLPHIN FORE & AFT

In order to minimize risks & communication problems associated with line handling



(HOLD) Do not slack or pull lines

Ne pas donner du mous ou tirer les amarres



(EASE OFF) Give slack as required

Donner du mous aux amarres



(HAUL IN) Slowly pull in the line

Tirer les amarres tranquillement